

Installation & Operation Manual

Swimming Pool Heat Pump



Model No.: EHP-007TF1

Thank you very much for purchasing our product.
Please keep and read this manual carefully before you install heat pump.

Fluorinated greenhouse gas – (R32)

The device contains the fluorinated greenhouse gas (R32) which is required for the device to work.

Industrial designation	HFC-32
Common designation	R32
Global warming potential (GWP)	675

Further information can be found on the device itself or the Specifications.

WARNING!

Risk of fire and explosion through leaking finned heat exchanger!

The refrigerant circuit of the finned heat exchanger contains highly pressurised, easily flammable, odourless gas. Risk of fire and explosion in the event of uncontrolled gas leakage.

- Action of filling gas must be conducted by professional with R32 operating license.
- Keep the heat pump away from heat sources and naked flames.
- Do not drill into or scorch the heat pump.
- Do not use any objects apart from those permitted by the manufacturer to speed up the defrosting process.
- Immediately shut off the heat pump if you suspect a gas leakage.
- The refrigerant is odourless. Always keep ignition sources away from the installation site of the heat pump.
- Contact an authorized expert if you suspect a gas leakage.

WARNING!

Risk of electric shock!

A faulty electrical installation or a mains voltage that is too high can lead to electric shock.

- Have the installation, initial start-up and maintenance of the heat pump carried out by authorized technician only.
- Please always cut the power supply if you want to open the cabinet to reach inside the heat pump as there is high voltage electricity inside.
- Only start work on the heat pump after checking all safety regulations.
- Only connect the heat pump if the mains voltage from the power socket matches the voltage indicated on the rating plate.
- Do not operate the heat pump if there is visible damage or the mains cable or the mains plug is defective.
- Do not open the housing. Leave repairs to qualified specialists. Liability and warranty claims are excluded in the event of repairs carried out on your own, improper operation.

- Ensure that children do not insert any objects into the fan blade and heat pump.
- Ensure that the electrical system to which the heat pump is connected has an earth conductor.
- If the unit would be installed where is vulnerable to lightning stroke, lightning protection measurements must be carried out.

 **ATTENTION!**

- The manufacturer declines any responsibility for the damage caused with the people, objects and of the errors due to the installation that disobey the manual guideline. Any use that is without conformity at the origin of its manufacturing will be regarded as dangerous.
- Please always keep the heat pump in the ventilation place and away from anything which could cause fire.
- Don't weld the pipe if there is refrigerant inside machine. Please keep the machine out of the confined space when make gas filling by the authorized technician.
- Please always empty the water in heat pump during winter time or when the ambient temperature drops below 0°C, or else the Titanium exchanger will be damaged because of being frozen, in such case, it will be out of warranty for this machine.

Content

1. Accessories description	4
2. Attention for safety	5
3. Installation of the unit	6
4. Specifications	9
5. Electrical Wiring	10
6. Instruction of operation	11
7. Adjusting and Initial operation	14
8. Operation and maintenance	15
9. Error codes & Solutions	17
10. Wireless / remote control	19
11. Fault analysis and elimination method	34
12. After-sale service	35
13. Warranty	36

1. Accessories description

Each unit produced by our factory is with the following accessories:

No.	Name	Qty.	Use
1	Instruction Manual	1 PC	Guide users to install the system
2	Drain-pipe	1 PC	Used for draining the condensate water
3	Drain-pipe connector	1 PC	Connect the drainpipe to the heat pump unit
4	Rubber shock absorber	4 PCS	Reduce vibration and reduce noise
5	Heat pump unit	1 SET	For heating water
6	Water connection	2 SET	Connect the piping system

For function you need to purchase at least the following parts for each unit:

No.	Name	Qty.	use
1	Water pump	1	Cycle the heated water
2	Filter system	1	Protect the heat pump from pool water
3	Water pipes system	1	Connect the equipment and make circulation

▲ NOTE

The types and quantity of the water pipes, valves, filter equipment, sterilizing equipment which used for the swimming pool heating/circulation pipe system, depend on the project design.

We suggest not to install auxiliary electric heaters in the system. If must install auxiliary electric heaters, it should be operated by the specialized persons, and our company has no responsibility for all the problem cause by the auxiliary electric heater.

Illustrations of machine

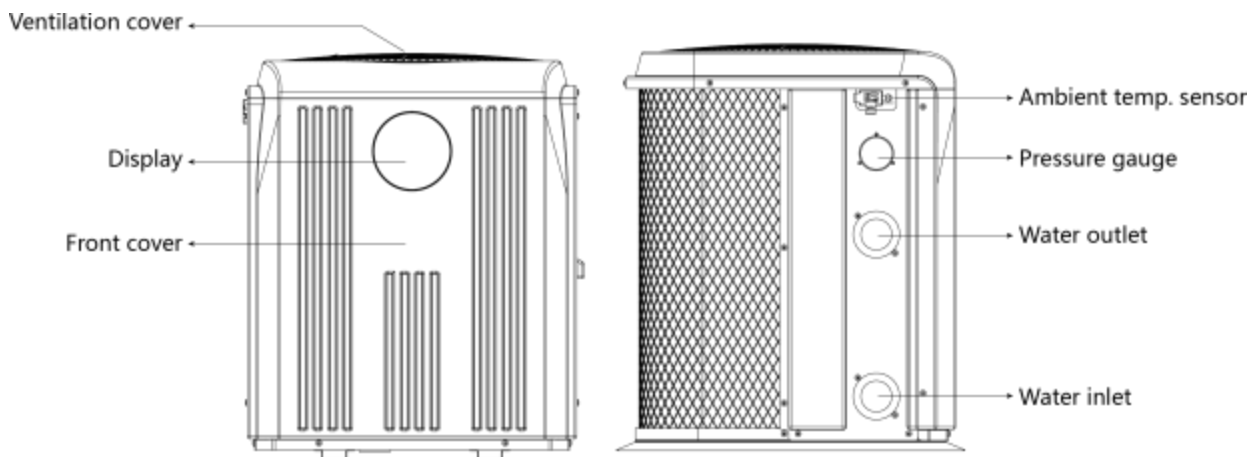

2. Attention for safety

Range of application:

1. Power supply: 220V/ 1/ 50-60Hz
2. Environment temperature: -15°C~43°C
3. Water temperature range: 8°C~40°C in Heating function
8°C~28°C in Cooling function

- Confirm the ground connection, if the ground connection is not correctly done, it may cause electric shock. And please cut off the power in the lightning storm weather.



- If install the heat pump in a small room, it must keep good ventilation.
- The main power switch should be out of the reach of Children.
- Don't put finger or stick into the air inlet or air outlet as the high-speed rotor may cause injury.
- When an exception happened (burning smell etc.), turn off the manual power switch immediately and contact with after-sale service department.
- When the unit needs to be removed or re-installed or repaired, please entrust after-sale service department and specialized personnel to do it. If the installation/ maintenance is not well done, it may cause unit operation failure, electric shock, fire, hurt, leaking, etc.
- Must not be unauthorized reformed, otherwise it may cause electric shock or fire.
- Must not install the unit with combustible around.
- Confirm the installation base is strong enough to avoid falling of the heat pump.
- Confirm leakage protection switch is installed to avoid electric shock or other issues.
- When cleaning the unit, the operation should be stopped, and power switch should be turned off.

3. Installation of the unit

3.1 Installation Illustration

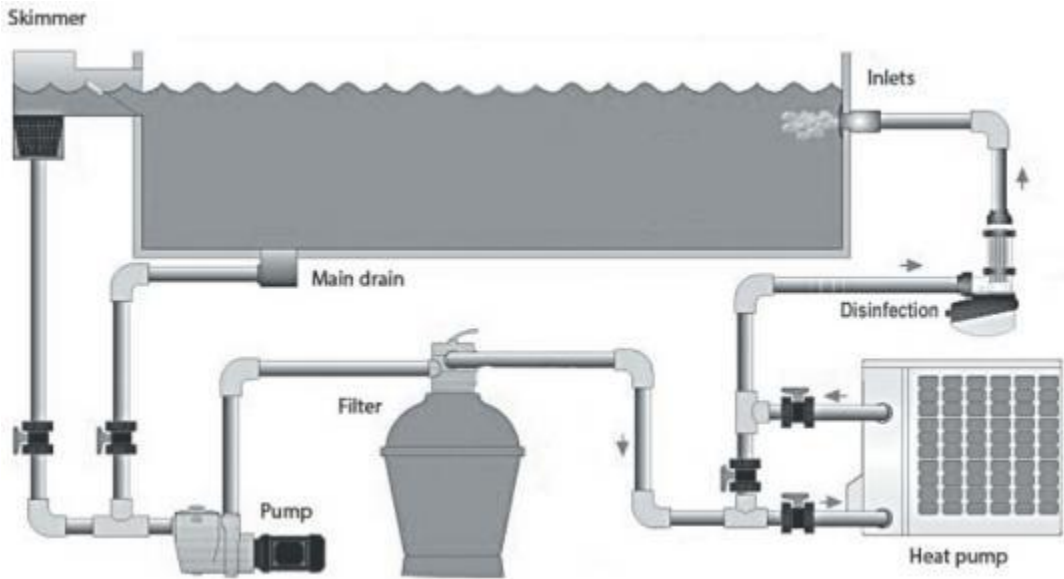

Above illustration is just for the reference, please take the advice of authorized installers.

3.2 Advised installation space

Keep the following indicated space for operation and maintenance when make the installation.

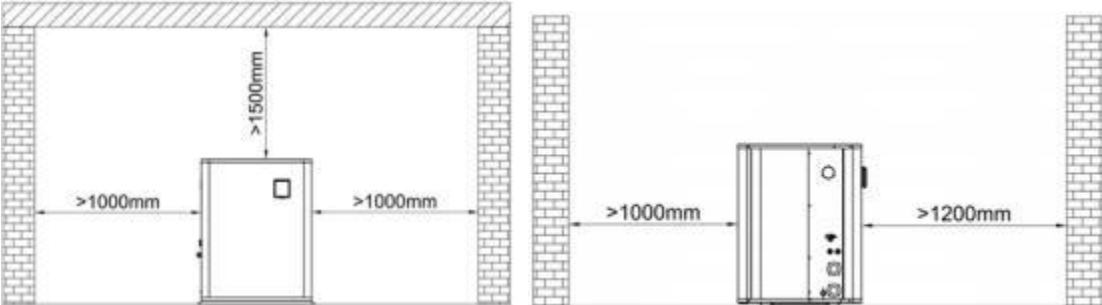

3.3 Additional By-pass kits

The additional By-pass kits is suggested to be put into the piping system to get the better adjustment of water flow.



3.4 Heat pump Exploded View

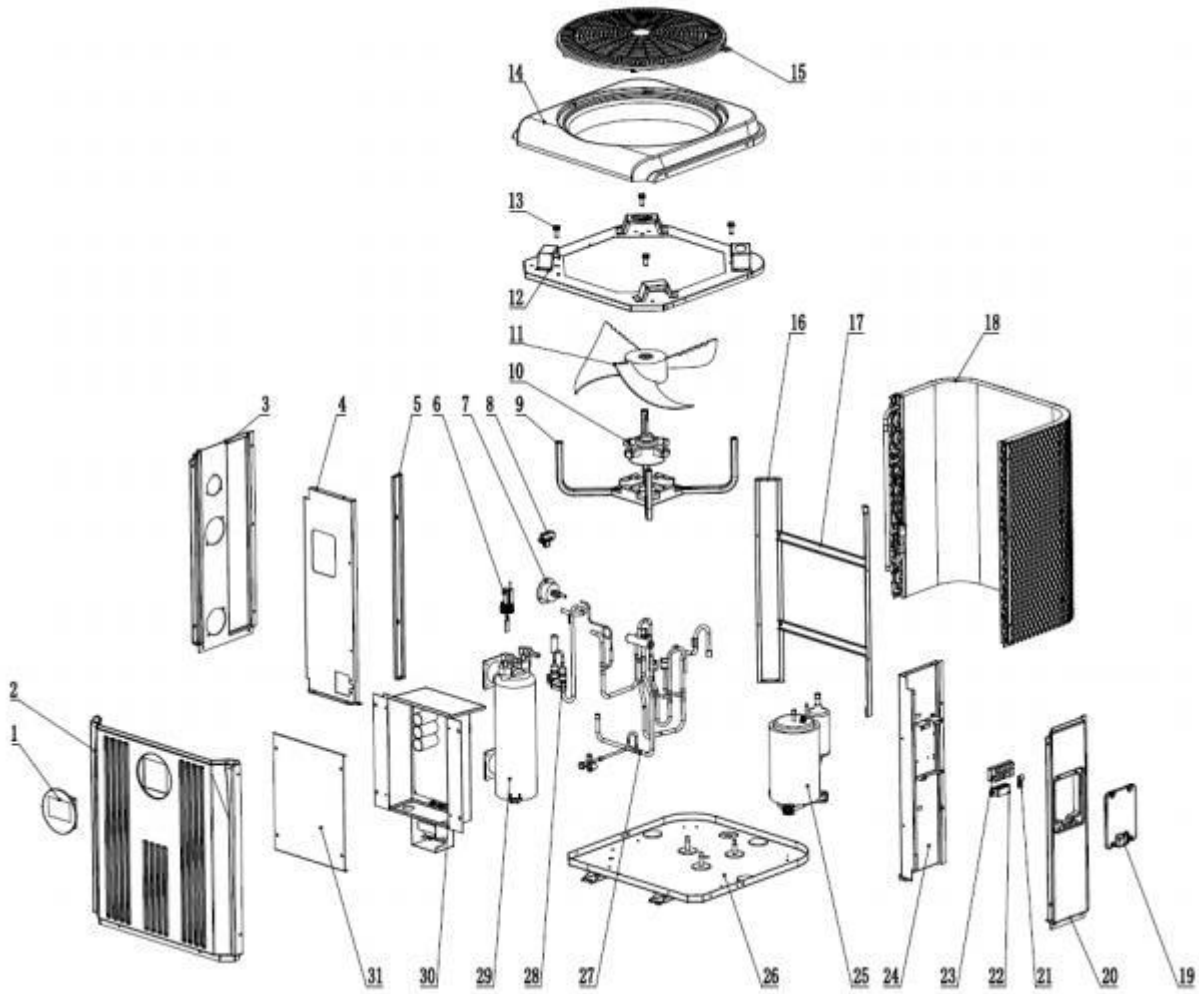

No.	Parts	No.	Parts	No.	Parts
1	Display	12	Top frame	22	Wire clip
2	Front panel	13	Bolt	23	Terminal
3	Side panel	14	Top cover	24	Pillar
4	Pillar	15	Ventilation	25	Compressor
5	Pillar	16	Pillar	26	Base tray
6	Water flow switch	17	Back frame	27	Four-way valve
7	Pressure gauge	18	Evaporator	28	EEV
8	Sensor clip	19	Wire cover	29	Titanium heat exchanger
9	Fan motor fixture	20	Side panel	30	Electric box
10	Fan motor	21	Wire clip	31	Electric cover
11	Fan blade				

3.5 Electrical connection

* Suggested power cable specification

Model	Power Cable Specification
EHP-007TF1	3*2.5 mm ²

* Electrical connection

Model: EHP-007TF1

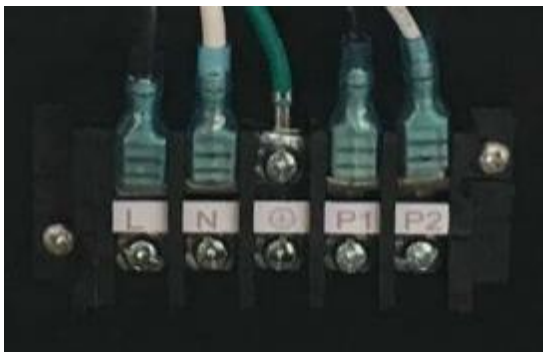

Position L,N and PE is for the power connection of our heat pump.

Position P1 and P2 is for the Single phase water pump.

Noted: There is another signal wire (the white one) inside the terminal cover which is reserved just for the long-distance operation. If you have this request, please you need buy additional 10-meter signal wire and a square type display to realize this function.

3.6 Condensation drainage

When machine running, there will be some condensation water on the base tray, which is the normal situation. Please you can use the drainage jet and hose at the bottom of machine to drain the condensation water. See below.



4. Specifications

4.1 Specifications

Model No .	EHP-007TF1
Advised pool volume(m³)	15~40
* Heating Capacity at Air 26℃ , Humidity 80%, Water 26℃ in, 28℃ out	
Heating Capacity (kW)	7.2~1.7
Power Input (kW)	1.06~0.11
COP	15.8~6.8
* Heating Capacity at Air 15℃ , Humidity 70%, Water 26℃ in, 28℃ out	
Heating Capacity (kW)	5.9~1.4
Power Input (kW)	1.2~0.18
COP	7.6~4.9
* Cooling Capacity at Air 35℃ , Water 29℃ in, 27℃ out	
Cooling Capacity (kW)	4.2~1.0
Power Input (kW)	1.11~0.15
EER	6.6~3.8
* General data	
Power supply	220~240V/ 1/50~60HZ
Max Power Input (kW)	1.45
Max Current (A)	7.1
Water Flow Volume (m³/h)	2.5
Refrigerant	R32
Heat Exchanger	Titanium
Air Flow	Horizontal
Direction	
Kind of defrost	by 4 way valve
Working temp. range (℃)	-15~43
Casing Material	ABS
Water Proof Level	IPX4
Noise level 1m dB(A)	41~51
Noise level 10m dB(A)	21~31
Net Weight (kg)	44
Gross Weight (kg)	55
Net Dimensions (mm)	530*530*640

* Above data are subjects to modification without notice.

5. Instruction of operation

5.1 Electric wiring diagram

Model: **EHP-007TF1**

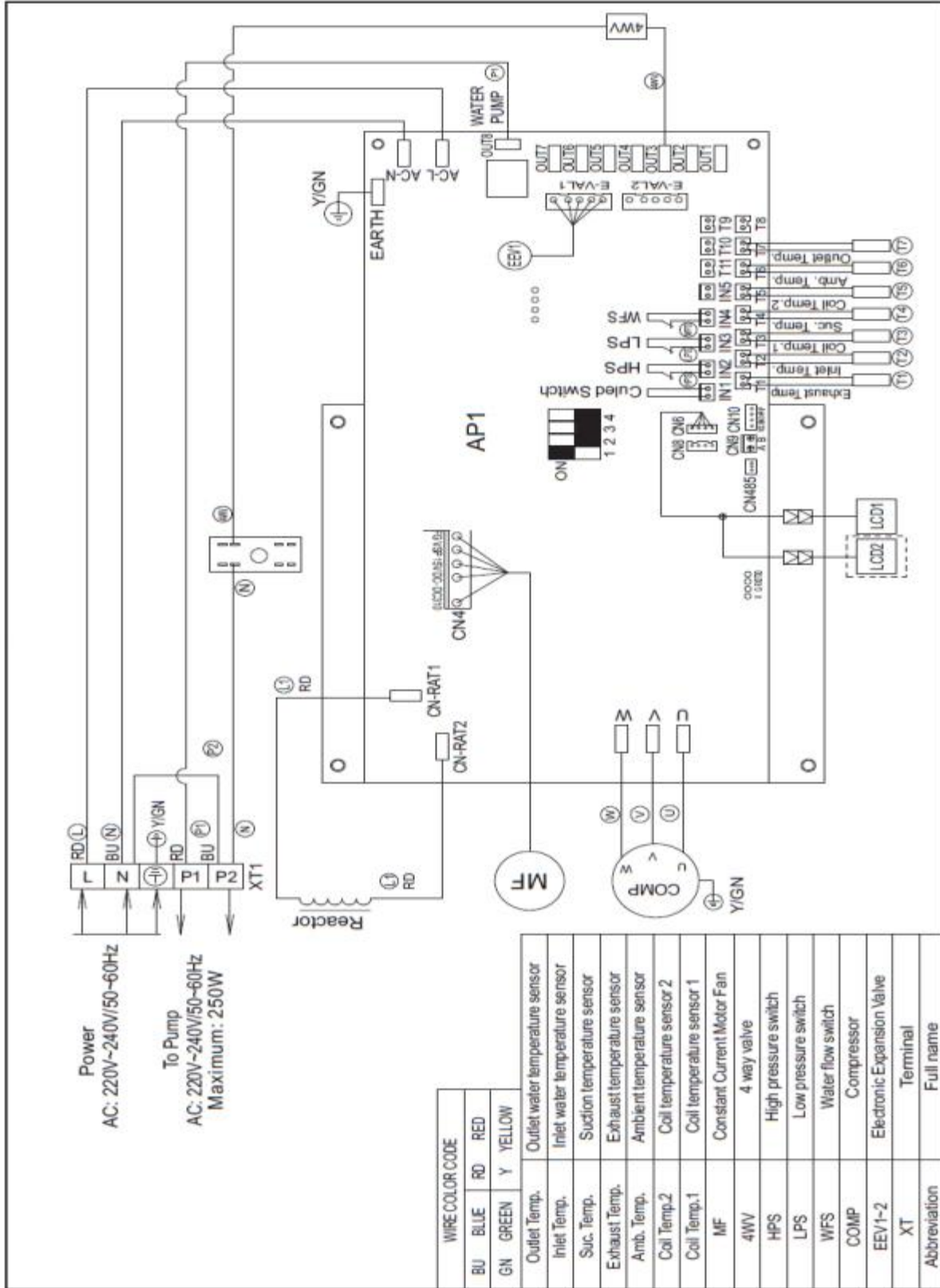



6. Instruction of operation

6.1 Wire controller interface



6.2 Start up & Locking

Hold the button  for 1 second to switch the heat pump on or off. This button is also used to return back to the main interface.

Hold the button  for 3 seconds to lock or unlock the display. (The lock will be activated automatically after 60 seconds of inactivity). When the display is locked, the logo  appears.





Note: Please unlock the controller before the other operations every time.

 **Attention:** Before you start, make sure the filtration pump is running and that water is flowing through the heat pump.

6.3 Operation function selected

Under main interface, press  to change the below three operation functions each time.

Auto  Heating  Cooling 

Under Auto function, if the real situation is in Heating, it will show  and , if the real situation is in Cooling, it will show  and .

6.4 Operation modes selected

Under main interface, press  to change the below three modes each time under Heating or Cooling function.





 **Silent mode:** Choose this mode that the heat pump operates silently.

an **Eco mode:** Choose this mode that the heat pump operates smartly.



aal **Powerful mode:** Choose this mode the heat pump operates powerfully.



Note: Under Auto function, the default mode is Eco mode and it can't be changed.







6.5 Set the required temp.

Under main interface, press  and  to adjust the desired water temp. of your pool, the icon  will light on, then press the  to save the setting.

6.6 Clock & Timer setting

Under main interface, hold  and  for 3 seconds to enter the Clock setting, hold them for 3 seconds again to enter the Timer setting, the  will flash.

Cancel timer: When you have set the Timer, under the Timer setting interface, hold  and  for 3 seconds again to cancel the Timer.

Clock or Timer setting: When you make the Clock or Timer setting, change the hours with  and , then press the  to go to minute setting, change the minutes with  and , press  to confirm the setting and return to the main interface.



Pay attention: There are 3 groups Timer for your every day setting.

6.7 Definition of other icons

 Water Inlet  Water outlet  Fan motor  Defrosting  Wi-Fi

Note: Under main interface, the Water inlet temp. and Water outlet temp. will display alternately.



6.8 Manual defrosting

Hold  and  for 3 seconds to start Manual defrosting function.

6.9 Factory setting recovery





Hold  and  and  and  for 5 seconds to recover factory setting.

6.10 Running Parameter checking

Hold  for 3 seconds to enter the Running parameters checking, then press  and  to check the below parameters as below:

Code	Description	Unit
A01	Inlet water temp.	°C
A02	Outlet water temp.	°C
A03	Ambient temp.	°C
A04	Exhaust temp.	°C
A05	Gas return temp.	°C
A06	Outer piping temp.	°C
A07	Inner piping temp.	°C
A08	EEV aperture	
A09	Compressor current	A
A10	Radiator temp.	
A11	Voltage value	V
A12	Frequency	Hz
A13	Fan motor speed	r/min
A14	Fan motor speed	r/min

6.11 Parameter setting

Hold  for 3 seconds to enter the Parameter setting, press  to select the parameter, then press  and  to set the new data for the below parameters.

Code	Description	Default	Scope
P01	Inlet water temp. in Heating mode	27°C	8~40°C
P02	Inlet water temp. in Cooling mode	27°C	8~28°C
P03	Inlet water temp. in Auto mode	27°C	8~40°C
P04	Water temp. difference before restart	1°C	1~18°C
P05	Heat pump ON/OFF when reached the desired water temp.	1	1 ON, 0 OFF

7.Adjusting and Initial operation

7.1 Attention

- Open the valve of water system, inject water into the system, and exhaust air inside.
- Do adjustment after electrical safety inspection.
- After the power is switched on, start the test running of heat pump, to check if it can function well.
- To avoid dangerous accident, the forced operation is forbidden.

7.2 Preparation Before Adjustment

- The system is installed correctly.
- Tubes and lines are putted in the right place.
- Accessories are installed.
- Ensure the smooth drainage.
- Ensure the perfect insulation.
- Correct connection of ground lead.
- The supply voltage can meet the requirement of rated voltage.
- Air inlet and outlet function can work well.
- Electrical leakage protector can work well.

7.3 Adjustment Process

- Check if the switch of the controller can work well.
- Check if the function keys of the controller can work well.
- Check if the drainage system can work well.
- Check if the system can work well after starting up.
- Check if the water outlet temperature is in correct situation.
- Check if there is vibration or abnormal sound when the system is functioning.
- Check if the wind, noise and condensate water produced by the system affect the environment around.
- Check if there is refrigerant leakage.
- If any Error codes occur, please check the instructions for the detailed info.

8. Operation and maintenance

8.1 To ensure the well functioning, the system should be checked and maintained after a period of time. During the maintenance, please pay attention to some points below:

- When you need open the cabinet and make inside inspection, please do cut off the electricity power in advance.
- To ensure the stable running, please do not adjust any setting.
- Pay close attention to whether all the operation parameters is normal during system working.
- Examine regularly whether the electrical connection is loose, if yes, fasten it on time.
- Examine regularly the reliability of the electrical components, change all the failed or unreliable components on time.
- The dirt retention on the surface of evaporator fin should be cleaned every 6 months.
- After long downtime, if we restart the equipment, we should make following preparations: examine and clean the equipment carefully, clean the water pipeline system, examine the water pump, and fasten all the wire connections.
- Replacement parts must use the original accessories, can not be replaced by other similar accessories.

8.2 Refrigerant filling

Examine the refrigerant filling condition through reading the data of gauge, also the air suction and exhaust pressure. If there is leakage or changing components of the refrigeration circulation system, please ask for the assistant of professional technicians.

8.3 Leak detection

During leak detection and air tightness experiment, never let the refrigeration system filling oxygen, ethane or other flammable harmful gas, we can only adopt compressed air, fluoride or refrigerant for such experiment.

8.4 Drainage water in heat exchanger

If the heat pump will be not used for a long time or in winter season, please do drain the water inside heat exchanger to avoid broken when freezing.

8.5 To remove the compressor, please follow the following steps

- Turn off the power supply
- Exhaust the refrigerant from the low pressure end, attention to reduce the exhaust speed, and avoid frozen oil leakage.
- Remove the compressor air suction and exhausting pipe.

- Remove the compressor power cables.
- Remove the compressor fixing screws.
- Remove the compressor.

8.6 Conduct regular maintenance according to the user manual instruction, to make sure the unit running in good condition.

- Fire prevention: if there is a fire, please turn off the power switch immediately, put the fire out with fire extinguisher.
- To prevent flammable gas: the unit working environment should stay away from gasoline, ethyl alcohol and other flammable materials, to avoid explosion accident.

9. Error codes & Solutions

Code	Description	Potential reasons	Solutions
	Water flow protection	Insufficient water flow	Check the water circuit system, the opening of by-pass kits, the running of water pump
		Water flow switch disconnected	Check the wiring and reconnect water flow switch
		Water flow switch defective	Change a new one
E04	Antifreeze protection	Ambient/Inlet water temp. is too low and the unit is on standby	The unit will be re-started when the ambient/inlet water temp. goes up.
E05	High pressure protection	Insufficient water flow	Check the water circuit system, the opening of by-pass kits, the running of water pump
		Ambient/ Water temp. is too high	
		Fan motor speed is abnormal or fan motor has damaged	Check the fan motor
		Excess refrigerant gas	Readjust the refrigerant volume
		High pressure switch disconnected or defective	Reconnect or replace high pressure switch
		Piping system jammed	Check the piping system
E06	Low pressure protection	Bad ventilation	Check the installation circumstance. Clean the evaporator. Check the running situation of fan.
		Low pressure switch disconnected or defective	Reconnect or replace low pressure switch
		Gas leakage (Check the gauge)	Detect the leakage point and make the maintenance
		Fan motor speed is abnormal or fan motor has damaged	Check the fan motor
		EEV blocked or piping system jammed	Check the piping system
E09	Connection failure between PCB and controller	Bad wire connection	Check the wiring
		Defective controller	Change a new controller
		Defective PCB	Change a new PCB
E10	Communication failure between PCB and driver module	Bad wire connection	Check the wiring
		Defective PCB	Change a new PCB
		Defective Driver module	Change a new driver module
E12	Exhaust temp. too high	Insufficient water flow	Check the water circuit system/ water flow-switch

		Lack of gas	Check if there is a gas leakage
		Piping system jammed	Check the piping system
		Exhaust piping temp. sensor defective	Change a new sensor
E15	Inlet water temp. sensor failure	Sensor disconnected or defective	Reconnect or replace sensor
E16	Outer piping temp. sensor failure	Sensor disconnected or defective	Reconnect or replace sensor
E18	Exhaust piping temp. sensor failure	Sensor disconnected or defective	Reconnect or replace sensor
E20	Inverter module abnormal protection		Check the voltage, compressor, fan motor etc...
E21	Ambient temp. sensor failure	Sensor disconnected or defective	Reconnect or replace sensor
E23	Overcooling protection under cooling mode	Insufficient water flow	Check the water circuit system/ water flow switch
		Outlet water temp. sensor failure	Change a new sensor
E27	Outlet water temp. sensor failure	Sensor disconnected or defective	Reconnect or replace sensor
E29	Suction piping temp. sensor failure	Sensor disconnected or defective	Reconnect or replace sensor
E32	Overheating protection under heating mode	Insufficient water flow	Check the water circuit system/ water flow switch
		Outlet water temp. sensor failure	Change a new sensor
E33	Piping temp. too high protection under cooling mode	Ambient/water temp. is too high under cooling mode	Check the scope of using
		Refrigerant system is abnormal	Check the piping system
E42	Inner piping temp. sensor failure	Sensor disconnected or defective	Reconnect or replace sensor
E46	DC fan motor malfunction	Bad wire connection	Check the wiring of fan motor
		Fan motor defective	Change a new fan motor

10. Wireless / remote control



WiFi Function 1



Step1: WIFI connection: The WIFI icon will flash to enter the WIFI connection status after power on.

It means the WIFI is successfully connected if the WIFI icon can be lighted over 5S. You can check the connection status in your mobile APP.

The WIFI icon is not lighted once WIFI connection is failed. Please reconnect following below 2 ways. →

- Method 1: Restart the controller.
- Method 2: Press and simultaneously hold three keys  +  for 5 seconds to reset the WIFI module, and then the WIFI icon will be flashed again).

Download and install the software:



User registration

When using the "smart life" software for the first time, user registration is required.

Click the "Create New User" link to enter the registration interface.

If you already have an account, just click login.

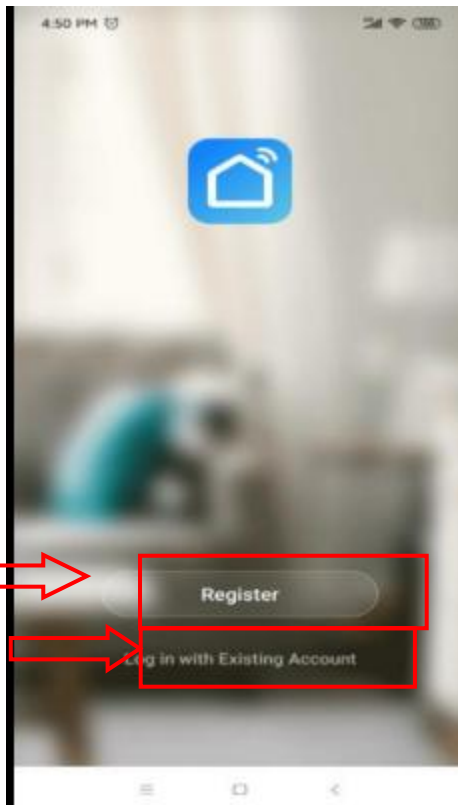

After entering the registration page, please follow the instructions on the page to register.

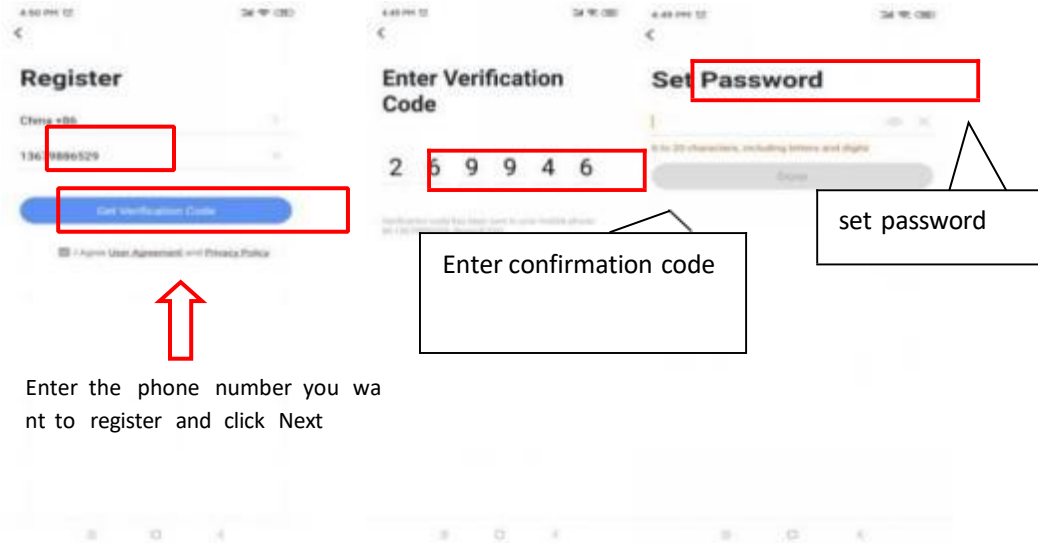

Enter the phone number you want to register and click Next

User login

After successful registration, the software will jump to the login interface or directly log in successfully, enter the correct "user name" and "password" to login.

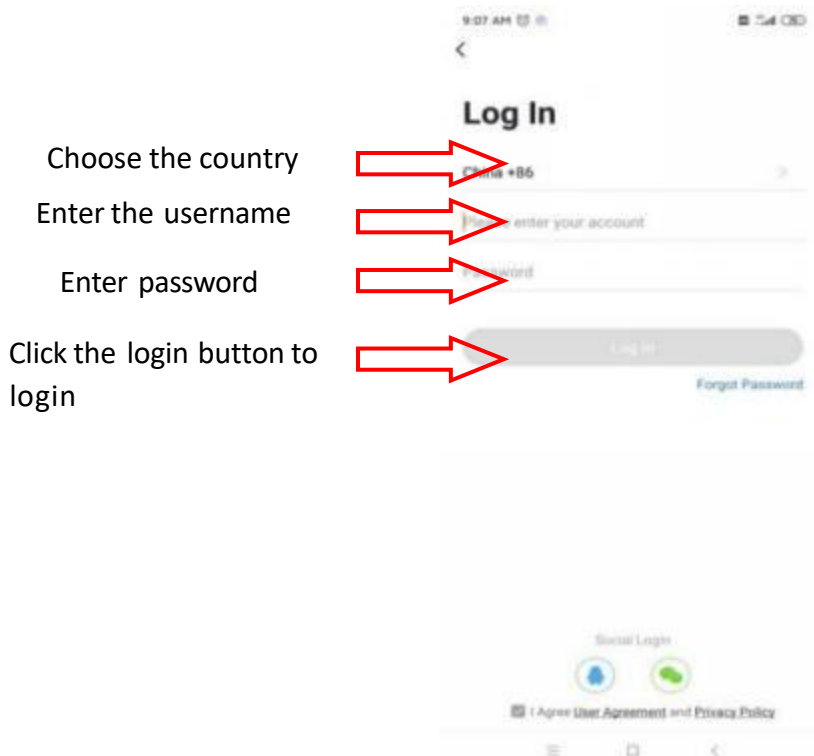

Choose the country

Enter the username

Enter password

Click the login button to login

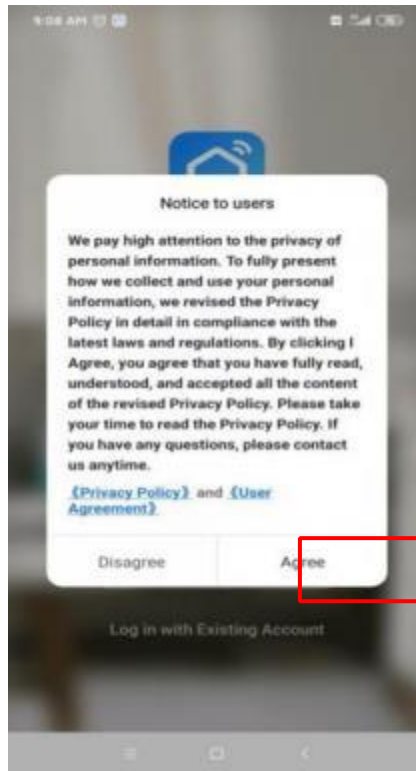

Need to select "Agree"

The phone needs to be connected to the network through the WIFI network

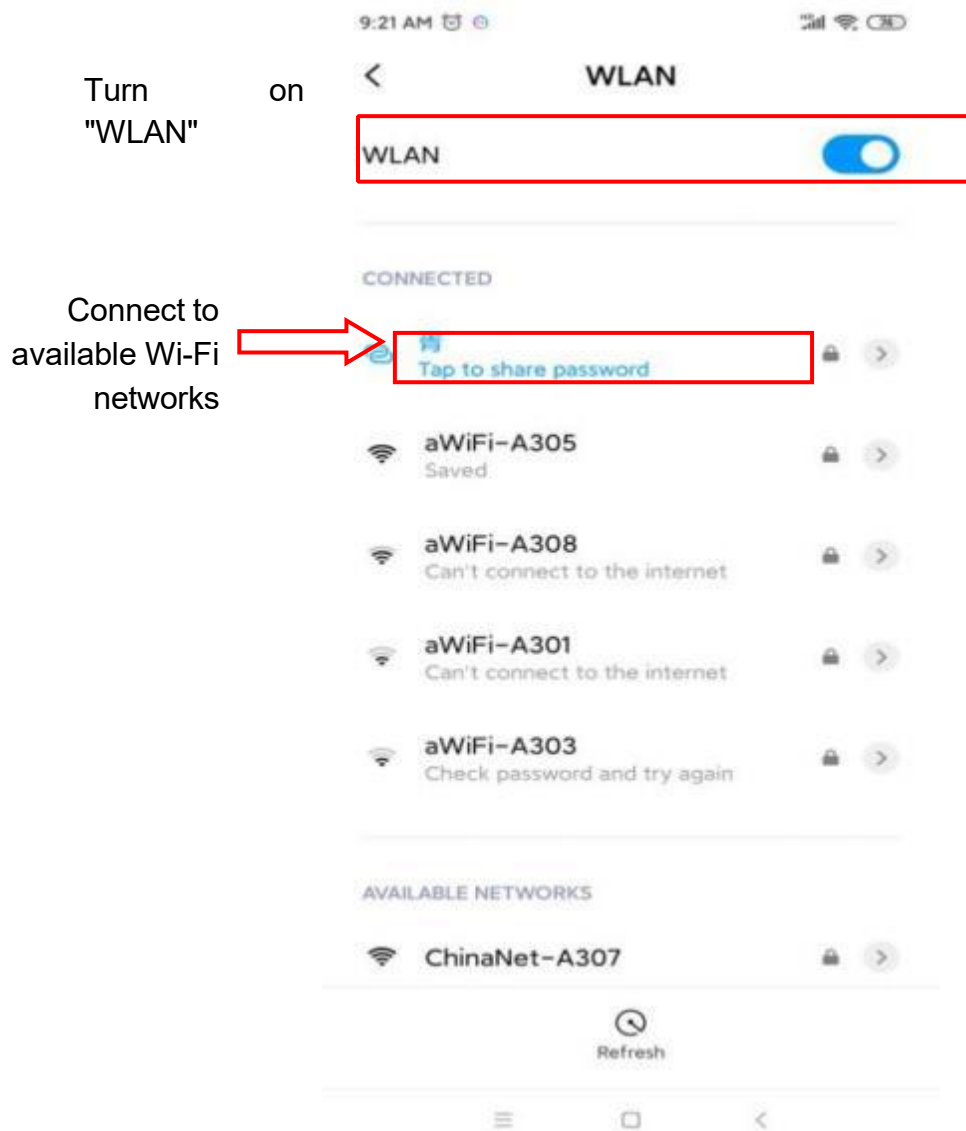

This WIFI is not the WIFI in the module but the WIFI that can be connected to the Internet;



After users login to the software, they can add devices

Device binding

Click "+" or "Add Device" in the upper right corner to bind.

Click to enter the "Add Device Type" interface

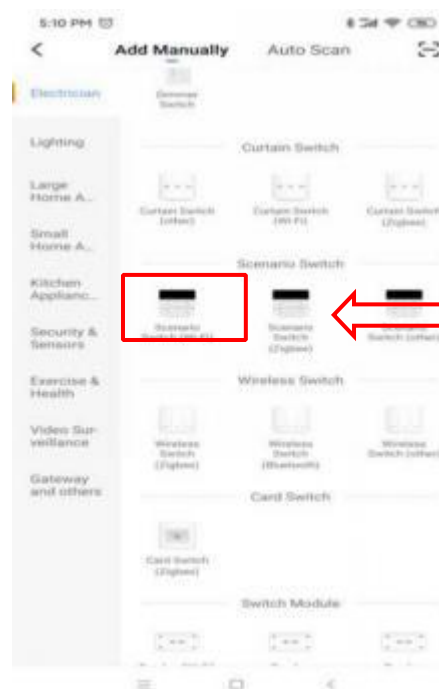
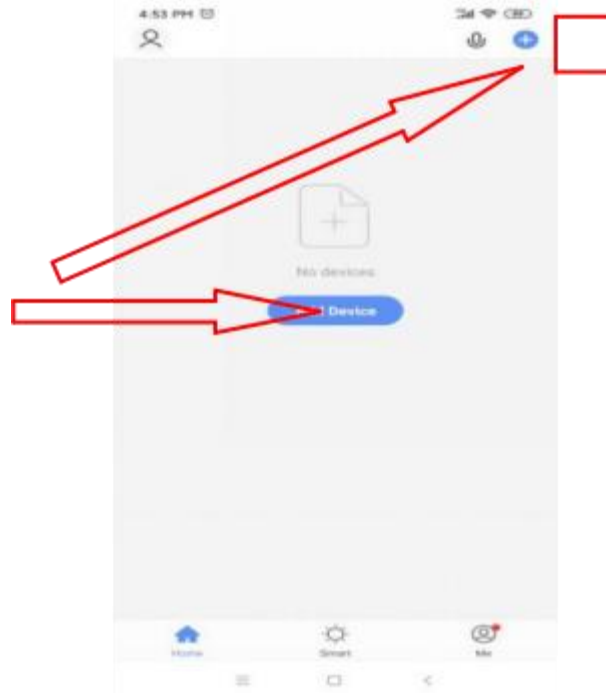

Choose "Icon Logo"

After completing the "Select Device Type", enter the "Add Device Interface", and the network configuration methods are divided into "default mode (WI-FI fast connection)" and "compatibility mode (hotspot distribution network)"

Default mode (WI-FI fast connection):

The remote controller simultaneously press the up key + mode key for 3 seconds to enter the "default mode" distribution network

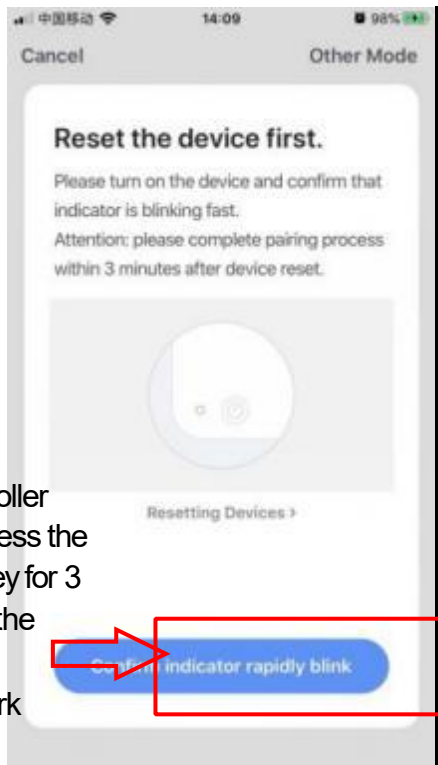

Enter the Wi-Fi password

Enter and click to confirm

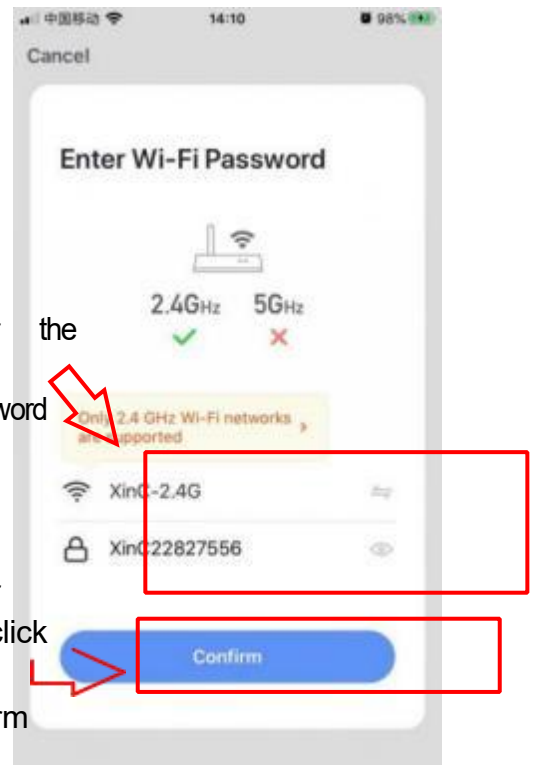

Enter the password and confirm it will jump to the connection interface

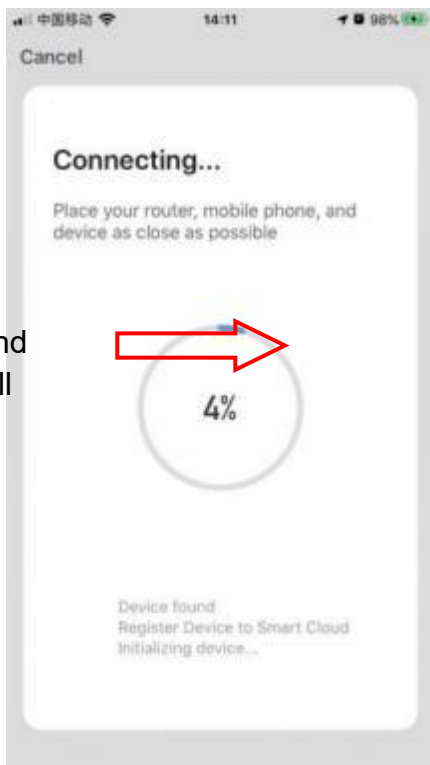

Device name can be modified

Click Finish to start device control

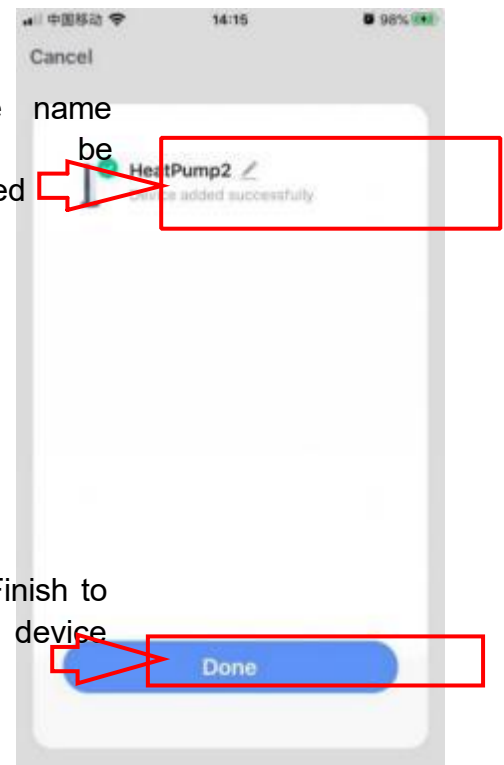

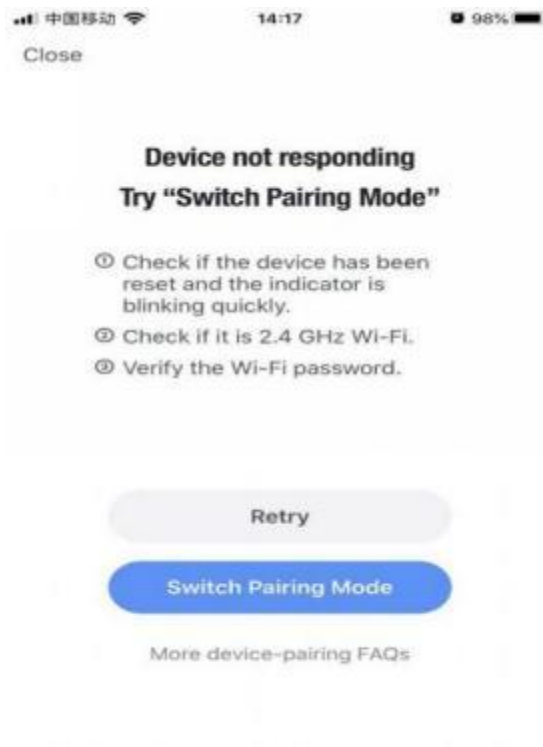

If the network distribution fails, the APP will display the page as shown in the figure, you can choose to re-add or view the help.

Compatibility mode :

Select "Other Ways" in the Add Device

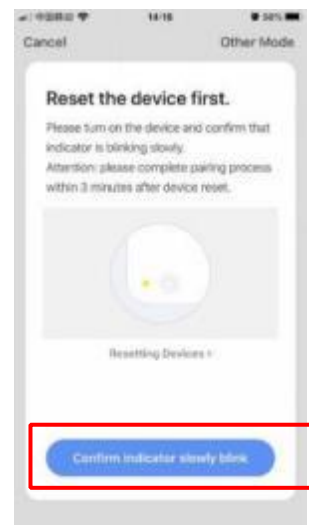
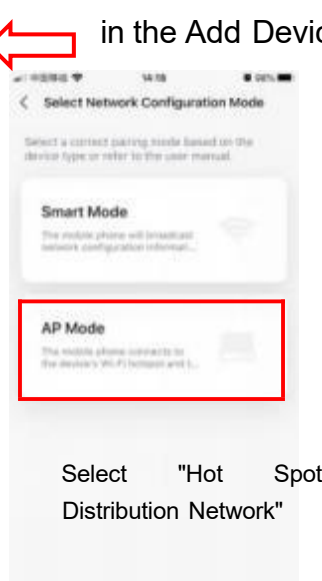
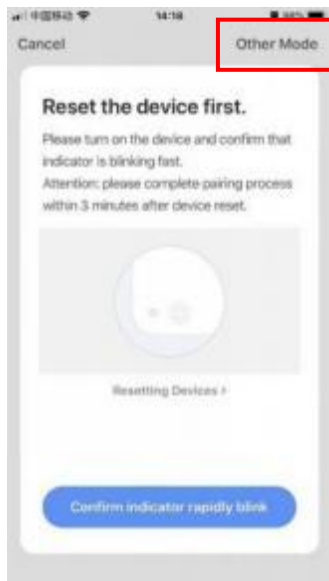

Press and hold the timing key +, down key +, power key simultaneously for 3 seconds to enter the "compatibility mode" distribution network.



Click Go to connect and jump to the Wi-Fi interface, select Wi-Fi with the words SmartLife-xxxx

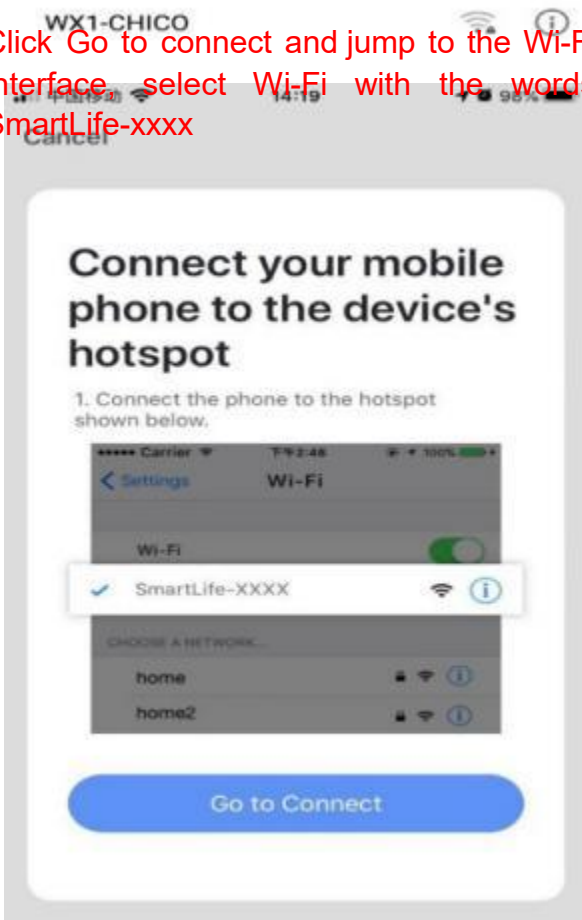

After selecting and connecting, return to the APP interface and enter the network distribution process

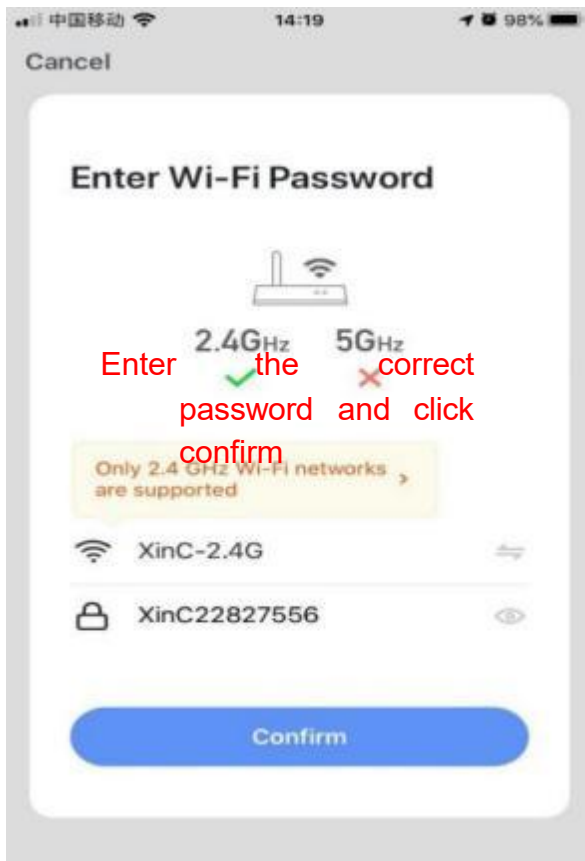

Control introduction

Successfully bound device



Click to enter control

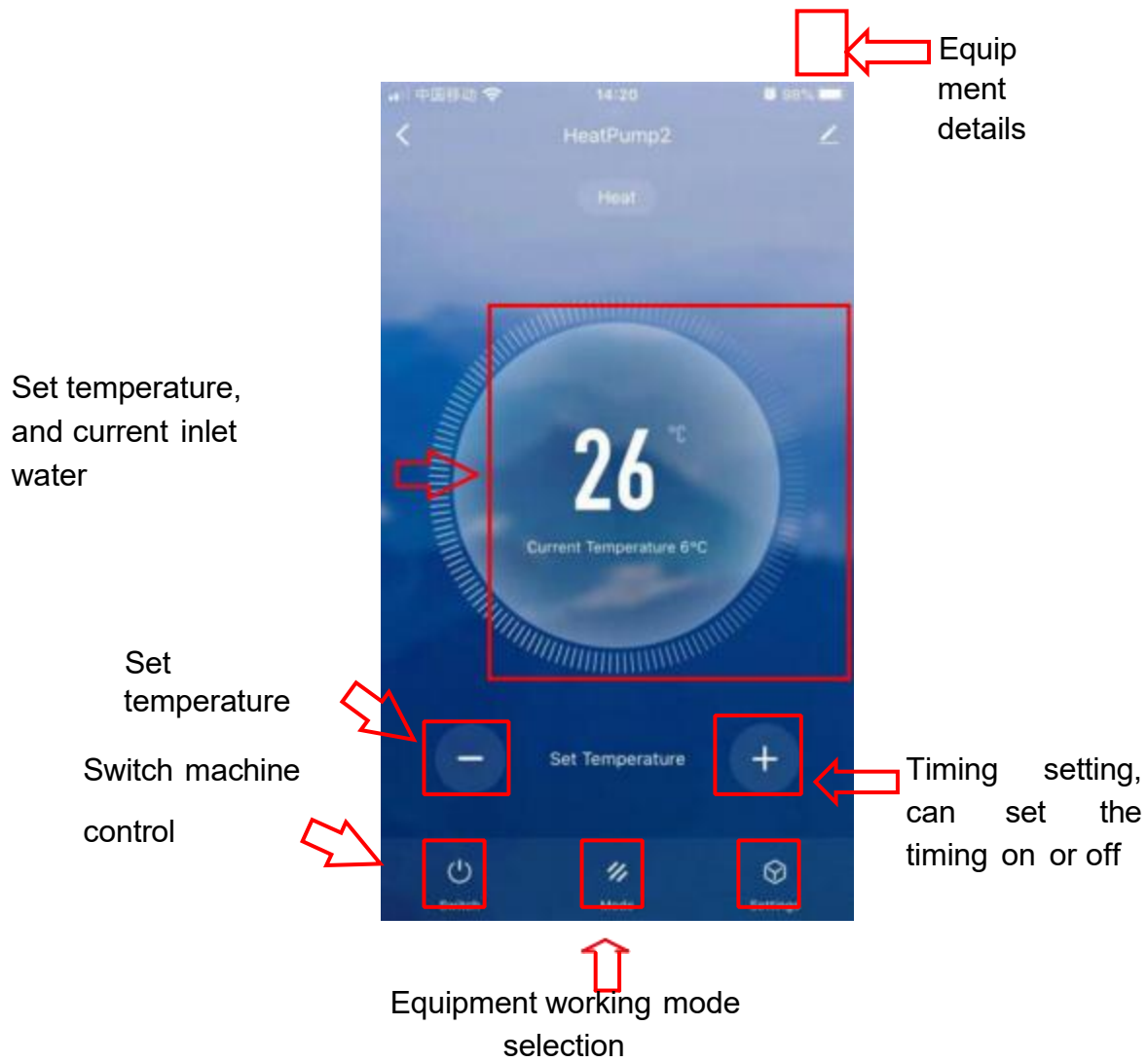

WIFI Function 2

1. Download the 'Tuya Smart' App

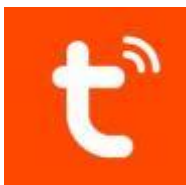

Scan the QR code below to download the mobile APP.



Or search 'Tuya Smart' in App Store (IOS) or Google play (Android)

2. Sign up for the first time

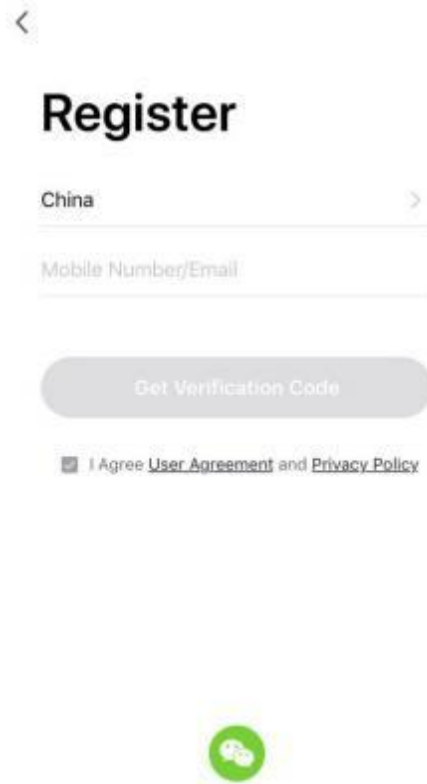
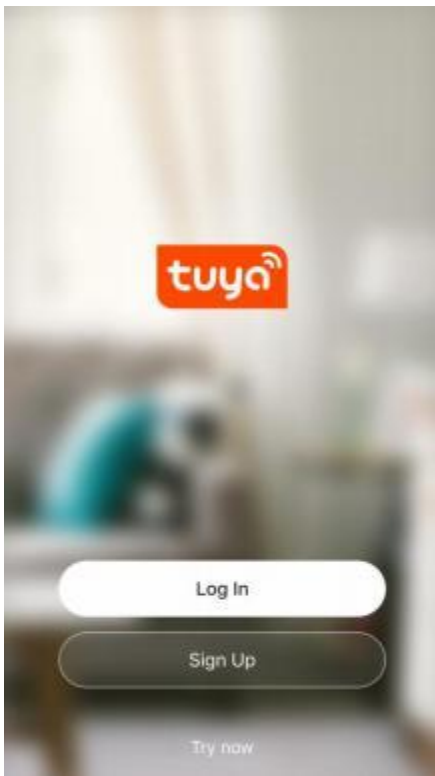

3. Press '+' to add a device
4. Choose 'Others' and 'Other Wifi' on the interface

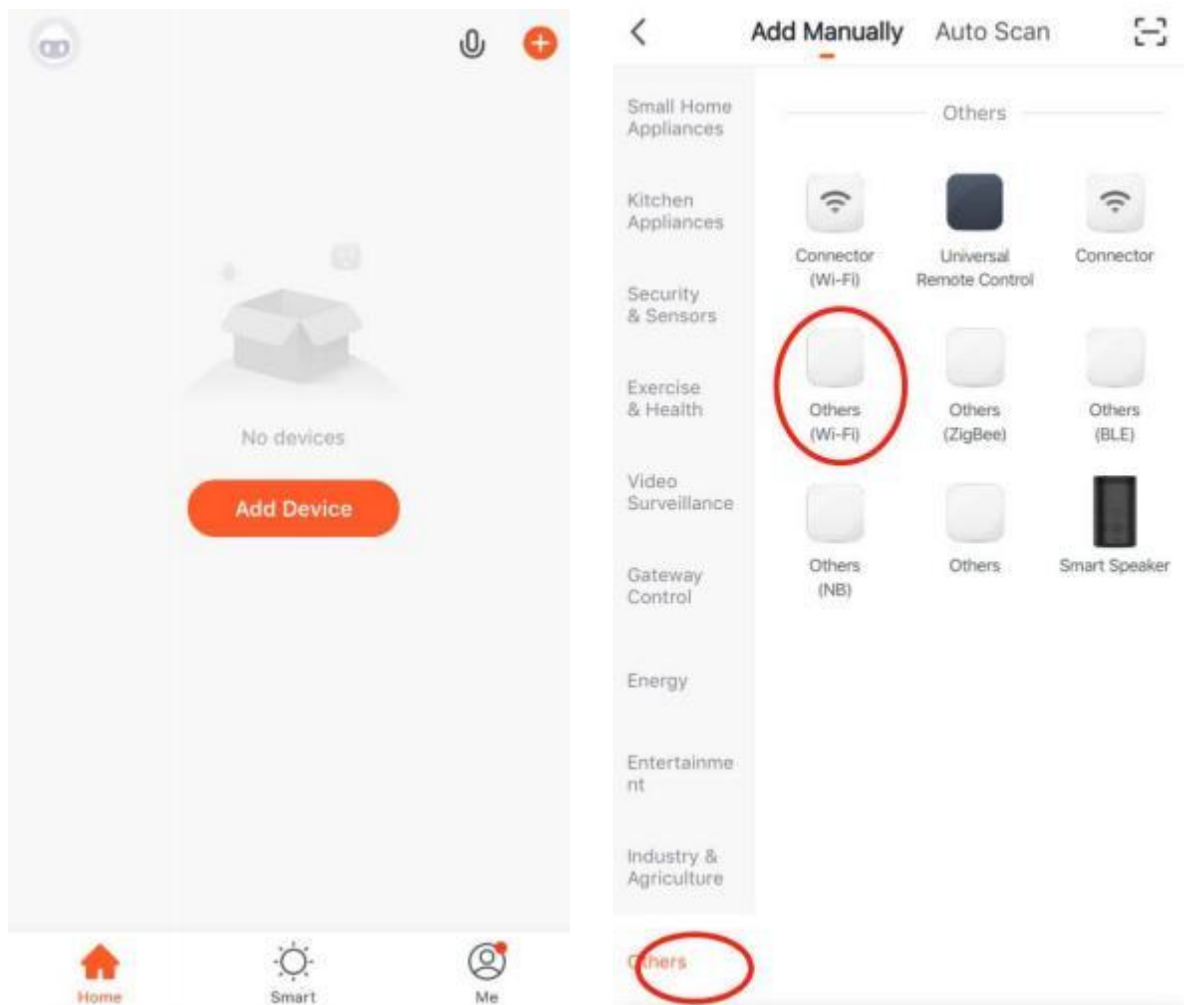

5. Put your mobile phone close to the pool heat pump, which are under the same Wifi area

6. Make sure the device is reset, then enter the WIFI account and password to connect Wifi.

Reset the Wifi function: Hold the  and  for 5 seconds, the  will flash quickly.

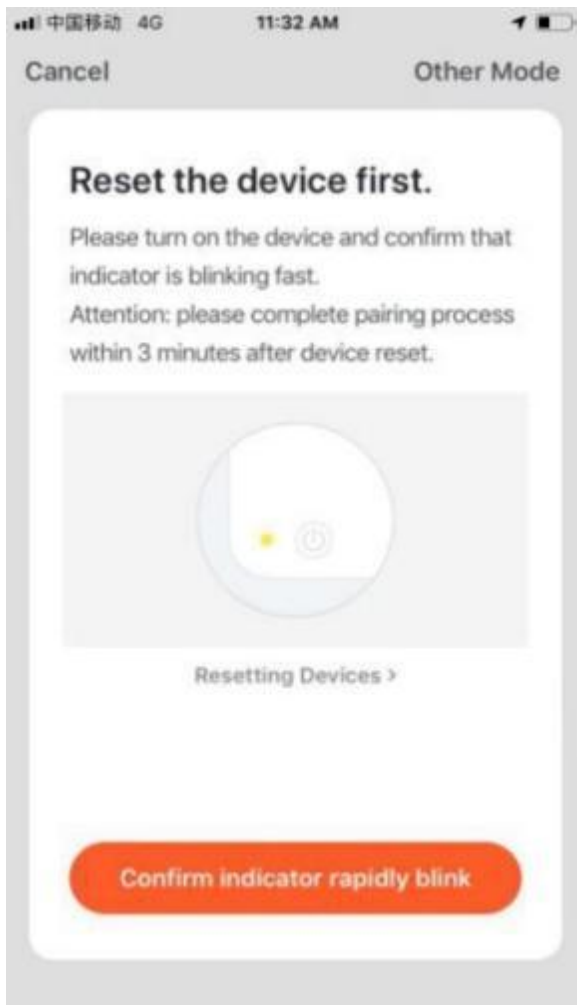

7. Press 'Confirm' to start the connection after completing. The device is successfully added if it's connect, then press 'Finish'.

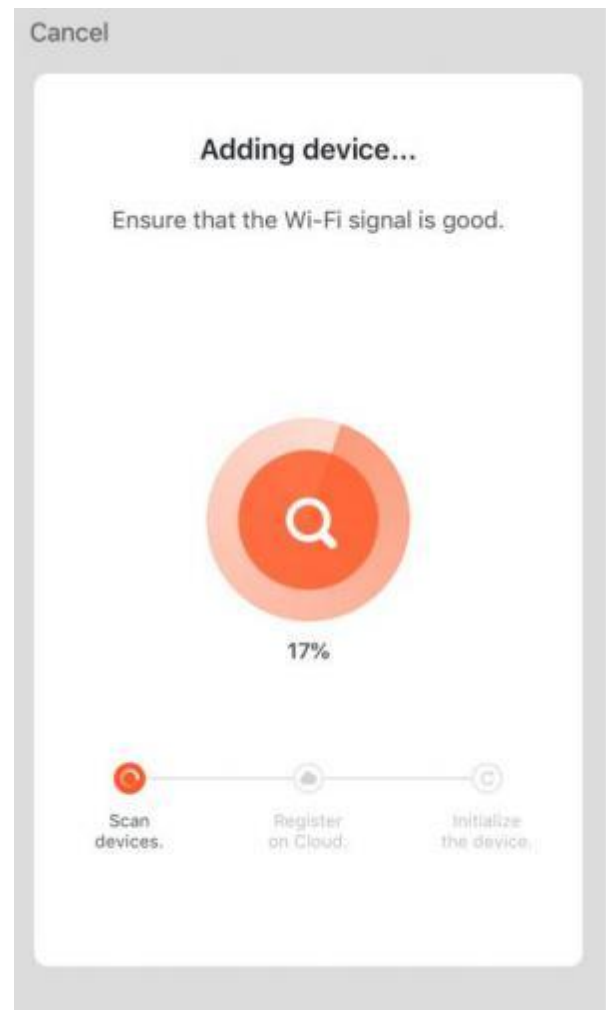
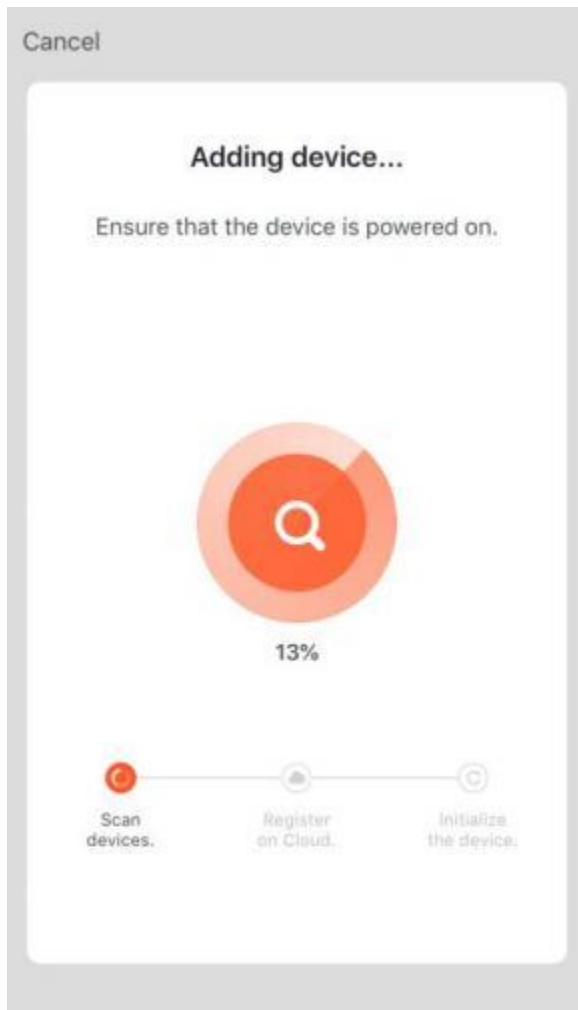

8. Functions

Remark: The heat pump APP function includes:

- Turn On/Off the machine
- Temperature setting and display
- Mode Selection
- Failure status display

11. Fault analysis and elimination method

Fault	Possible cause	Detection and elimination method
Discharge pressure is too high.	<ul style="list-style-type: none"> ◆ There is air or other non-condensable gas existed in the system. ◆ Water heat exchanger is scaling or fouling blockage. ◆ The circulation water volume is not enough. ◆ Refrigerant charging is too much. 	<ul style="list-style-type: none"> ● Vent the air from water heat exchanger ● Wash and clean the water heat exchanger ● Examine the water system pipeline and pump. ● Drain part of the refrigerant
Discharge pressure is too low.	<ul style="list-style-type: none"> ◆ Liquid refrigerant flow through evaporator to compressor, which make foam for the frozen oil ◆ Suction pressure is too low ◆ Refrigerant charging is too less, the refrigerant air goes into liquid pipeline 	<ul style="list-style-type: none"> ● Examine and adjust the expansion valve, make sure the expansion valve temperature sensor bulb is close connected with the air suction pipe, and absolutely insulated with the ambient environment. ● Please refer to "Fluorine filling if suction pressure too low"
Suction pressure is too high.	<ul style="list-style-type: none"> ◆ Discharge pressure is too high. ◆ Refrigerant charging is too much. ◆ Liquid refrigerant flow through evaporator to compressor. 	<ul style="list-style-type: none"> ● Drain part of the refrigerant. ● Examine and adjust the expansion valve, make sure the expansion valve temperature sensor bulb is close connected with the air suction pipe, and absolutely insulated with the ambient environment.
Suction pressure is too low.	<ul style="list-style-type: none"> ◆ Ambient temperature is too low. ◆ The evaporator liquid inlet or compressor suction pipe is blocked, expansion valve unadjusted, or failed. ◆ The refrigerant is not enough in the system. 	<ul style="list-style-type: none"> ● Adjust suitable overheat temperature, examine whether there is Fluorine leakage from the expansion valve temperature sensor bulb. ● Examine Fluorine leakage. ● Examine the installation condition
Compressor stopped because of high pressure protection.	<ul style="list-style-type: none"> ◆ The water inlet temperature is too high, circulation water is not enough. ◆ The high pressure stop setting is not correct, the air suction overheat greatly. ◆ Fluorine filling is too much. 	<ul style="list-style-type: none"> ● Examine water system pipeline and water pump. ● Examine the high pressure switch. ● Examine the Fluorine filling volume, drain part of refrigerant.
Compressor stopped because of motor overloading.	<ul style="list-style-type: none"> ◆ The voltage is too high or too low. ◆ Discharge pressure is too high or too low. ◆ Device loading failure. ◆ Ambient temperature is too high. ◆ Motor or connecting terminal is in short circuit. 	<ul style="list-style-type: none"> ● The voltage should be controlled within more or less 20V than rated voltage, and phase difference within $\pm 30\%$. ● Examine the compressor current, compare with the full loading current indicated in the user manual. ● Improve air ventilation.
Compressor stopped because of built-in thermostat.	<ul style="list-style-type: none"> ◆ The voltage is too high or too low. ◆ Discharge pressure is too high. ◆ The refrigerant in the system is not enough. 	<ul style="list-style-type: none"> ● Examine the voltage to make sure it is within the specialized range. ● Examine the discharge pressure and find out the reason. ● Examine whether there is Fluorine leakage.
Compressor stopped because of low voltage production	<ul style="list-style-type: none"> ◆ Dry filter clogging. ◆ Expansion valve failure. ◆ The refrigerant is not enough. 	<ul style="list-style-type: none"> ● Examine, maintain, or change dry filter. ● Adjust or change expansion valve. ● Fill in refrigerant.
High noise of compressor	<ul style="list-style-type: none"> ◆ There is liquid hammer for liquid refrigerant flowing through evaporator to compressor. 	<ul style="list-style-type: none"> ● Adjust liquid supply, examine whether normal for the expansion valve and air suction over heat degree.
Compressor can not start.	<ul style="list-style-type: none"> ◆ Over current relay is tripped, insurance is burn. ◆ The control circuit is not connected. ◆ No current. ◆ The pressure is too low, which can not conduct the pressure switch. ◆ The contactor coil is burn out. ◆ Water system failure, relay is tripped. 	<ul style="list-style-type: none"> ● Set the control circuit in manul mode, restart the compressor after maintenance. ● Examine controlling system. ● Examine power supply. ● Examine whether the refrigerant is too less. ● Reconnect, adjust two of the wiring.

12.After-sale service

If your heat pump does not operate normally, please turn off the unit and cut off the power supply at once, then contact our service center or technical department.

13. Warranty

13.1 Warranty Periods

- The entire unit is covered by a **2-year** warranty.
- The compressor is covered by a **2-year** warranty.

13.2 Warranty Conditions

- The warranty covers only the free replacement of defective parts, provided that the parts are confirmed to be faulty and in need of replacement.
- For any warranty claim, the following documentation must be provided:
 - ❖ Detailed fault description.
 - ❖ Photographs or videos of the fault.
 - ❖ Relevant maintenance records.

13.3 Replacement Parts

- Replacement parts, including components related to the power supply, will be provided during the warranty period.
- The company does not assume responsibility for labor costs or any other expenses related to after-sales service.

13.4 Technical Support

- The Technical Support Department will provide assistance with product installation and maintenance as need